



10 Russell Street Tootgarook VIC

3 1 2

Updated interiors, light filled spaces and with amazing potential to add future value - this immaculate three bedroom family beach house will be sure to impress!

Set on an impressive level allotment of over 750*m² and positioned just 850*m approx to the entrance of the Tootgarook foreshore and Bay Trail, from this location you are also only a short drive in either direction to a fantastic array of shopping and restaurant options.

Featuring

- Polished hardwood flooring throughout
- Brick construction
- Three bedrooms
- Level allotment of approximately 758*m²
- Located approximately 850*m to the Foreshore & Bay

Price : \$ 980,000
Land Size : 758 sqm
View : <https://www.ypa.com.au/7393506>



Tony Talarico
0420 778 401

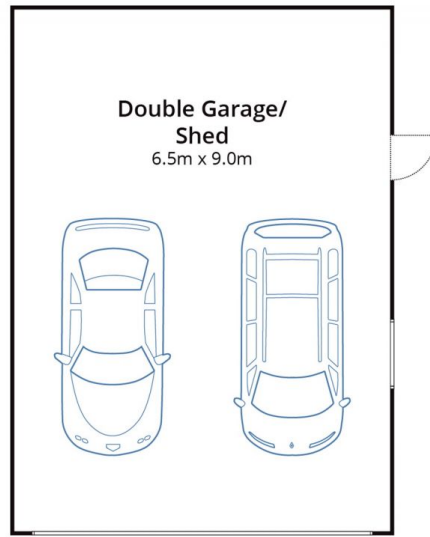

(Not In Position)

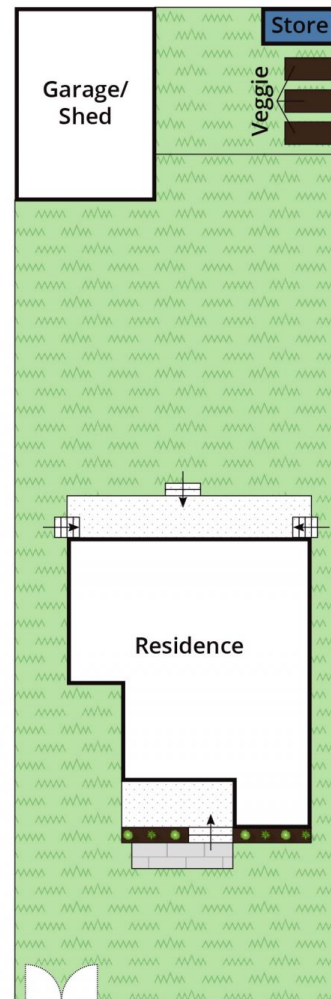

Approx House Area 129m²

Approx Land Area 758m²

Whilst bvr.com.au has made every attempt to ensure the accuracy of the floor plan contained here, measurements are approximate and no responsibility is taken for any error, omission, or mis-statement. This plan is for illustrative purposes only.

10 Russell Street, Tootgarook